

NEW FROM MX



2 NEW MODELS:
MX C4 & C4+



C1

C2

C3u

C3

C3+

C4

C4+

MX C4 and C4+

2 new COMPACT loaders
for tractors from 40 to 70 hp



RAISE YOUR EXPECTATIONS

THE RANGE OF MX COMPACT LOADERS

A SOLUTION FOR EVERY REQUIREMENT



CLEAR LINK SYSTEM parallelogram

- > Complete integration
- > Panoramic visibility
- > Reduced maintenance costs



NEW MACH System COMPACT



HYDRAULIC INTEGRATION

- > Hoses concealed inside loader
- > Protected hydraulic unit
- > Instant connection with the MACH System
- > Rounded, fluid lines



CONTROLLED PERFORMANCE

- > Excellent crowd back at ground level
- > Optimal dumping at full height
- > Very compact tractor-loader unit

TECHNICAL SPECIFICATIONS

	NEW						
	MX C1	MX C2	MX C3u	MX C3	MX C3+	MX C4	MX C4+
Mechanical parallelogram	NO	NO	NO	NO	YES	NO	YES
MACH System (instant hydraulic connection)	NO	NO	YES	YES	YES	YES	YES
Automatic hitching of implements	NO	NO	NO	YES	YES	YES	YES
Indicator rod	NO	NO	NO	YES	YES	YES	YES
Nominal tractor power	15-25 hp	18-30 hp		20-50 hp		40-70 hp	
Maximum height at implement pivot*	1.92 m	1.92 m	2.60 m	2.60 m	2.60 m	2.90 m	2.90 m
Max. height under horizontal bucket (2)	1.80 m	1.80 m	2.40 m	2.40 m	2.40 m	2.70 m	2.70 m
Max. height under dumped bucket (1)#	1.50 m	1.50 m	2.05 m	2.05 m	2.05 m	2.30 m	2.30 m
Digging depth #	0.10 m	0.10 m	0.15 m	0.15 m	0.15 m	0.15 m	0.15 m
Max. dump angle at full height (3)#	40°	40°	35°	50°	50°	50°	50°
Dumping angle at ground level (7)#	125°	125°	127°	140°	140°	140°	140°
Crowd angle at ground level (4)#	30°	30°	25°	45°	46°	45°	45°
Front dumping range (6)#	900 mm	900 mm	960-1060mm	960-1060mm	960-1060mm	850-1150 mm	850-1150 mm
Lifting force of implement on axis of rotation*	450 kg	450 kg	750 kg	750 kg	750 kg	1100 kg	1100 kg
Lift capacity at implement pivot over the entire lifting range*	420 kg	420 kg	740 kg	740 kg	740 kg	1100 kg	1100 kg
Payload**:							
> on ground *	390 kg	390 kg	510 kg	420 kg	530 kg	700 kg	900 kg
> 1 m from ground	370 kg	370 kg	520 kg	440 kg	530 kg	730 kg	900 kg
> 2 m from ground	-	-	500 kg	430 kg	530 kg	690 kg	900 kg
> at max. height	350 kg	350 kg	470 kg	380 kg	530 kg	620 kg	900 kg
Lifting time	3 s	3 s	4.5 s	4.5 s	4.5 s	3.9 s	3.9 s
Dumping time	3 s	3 s	2.1 s	2.2 s	2.2 s	1.7 s	1.7 s
Weight (without equipment)	85 kg	90 kg	200 kg	220 kg	240 kg	230 kg	270 kg

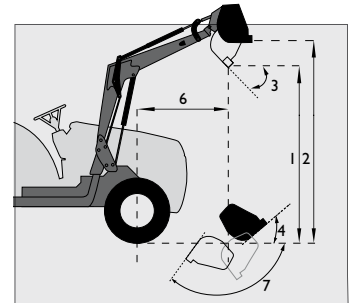

Data may vary depending on the type of tractor being equipped

Characteristics measured at:

- pressure of 140 bar and flow rate of 15 litres/min for MX C1.

- pressure of 140 bar and flow rate of 20 litres/min for MX C2/C3u/C3/C3+/C4/C4+

* Only safe working loads apply. The figures at ground level and at the implement pivot axis are not to be used

** MX C3/C3+/C4/C4+: Payload at 70 cm from the implement's pivot axis
MX C1/C2/C3u: Payload with general purpose bucket

Figures provided for a multipurpose bucket