



ENERGYA



CIFA ®
A ZOOMLION COMPANY

MORE THAN JUST A RANGE: IT IS AN ECOSYSTEM

BEE* 
the Change

*BEE Battery Electric Equipment

A fleet of machinery unlike any other in the world designed to be both efficient and sustainable.

CIFA's focus on technological innovation is reflected in the development of the world's first range of electric vehicles since 2013, helping to pave the way for a new era in which performance and ease of use go hand in hand with environmental protection. It is, in fact, a revolution in the world of machinery for the transport and pumping of concrete. The watchword is "SUSTAINABILITY", with the reduction of environmental impact the only condition to create a sustainable "jobsite".

**Efficiency in sustainability:
this is the commitment of a range
of machines unique in the world.**





BATTERY ELECTRIC EQUIPMENT



THE FIRST AND ONLY ELECTRIC RANGE IN THE WORLD

CIFA was a pioneer in the conception of Battery Electric Equipment (B.E.E.) capable of operating without external energy sources. CIFA ENERGYA is a full range of tangible and tailored solutions which started with the transport of concrete (truck mixer) and then sprayed concrete (spritz pump), has been expanded even further with a machine for transport and installation (Pump Mixer), the stationary pumps and with the new electric truck pump.



Lower consumption
less emissions less noise



No compromise on
performance



Lower
maintenance costs



Less noise

CONCRETE PLANT

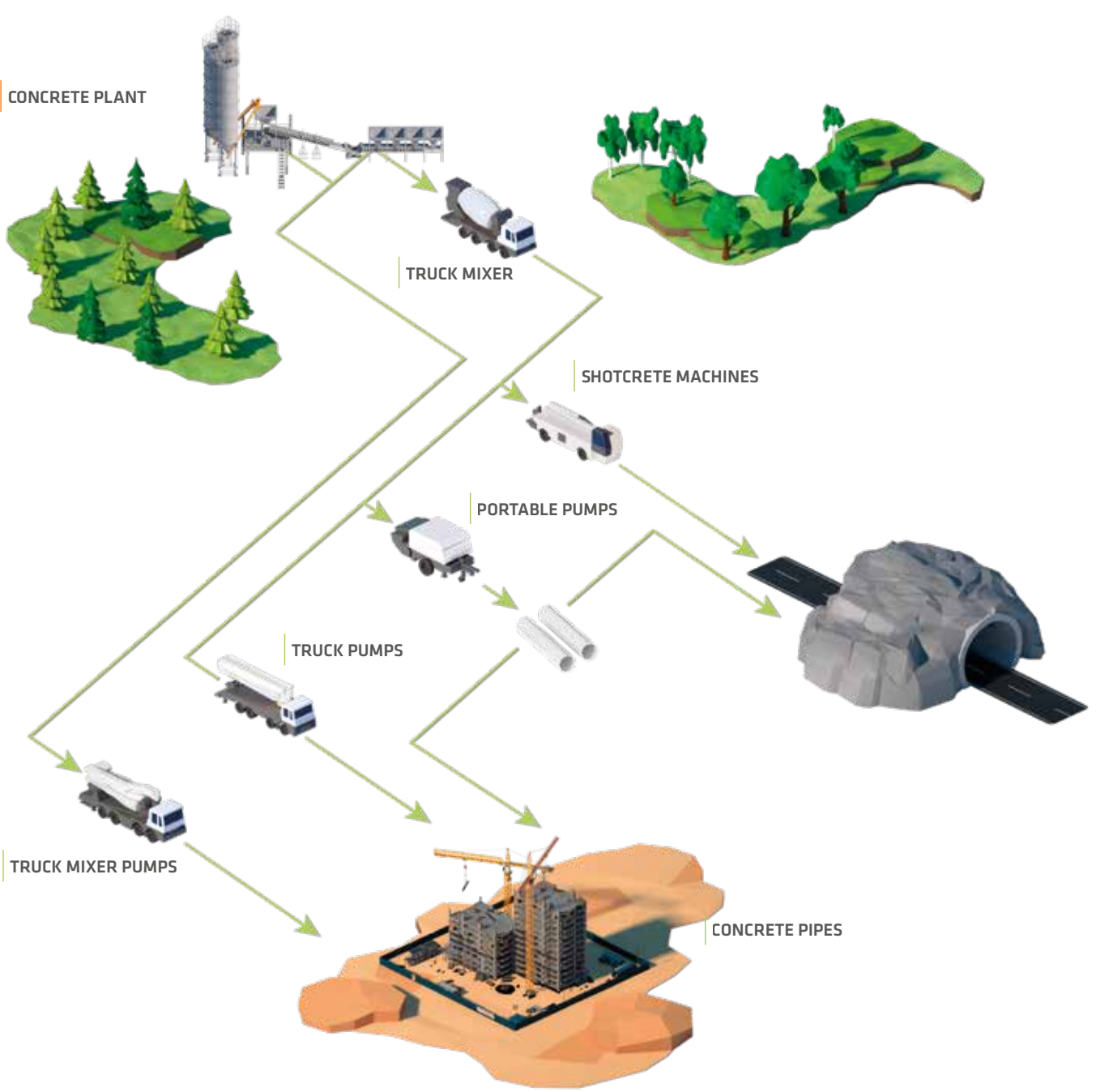

BEE

BATTERY ELECTRIC EQUIPMENT

The focus of this range is the upper structure. Each machine type has an integrated battery, therefore, it will always run in electric mode no matter which kind of truck is used (I.C.E. or B.E.V.).

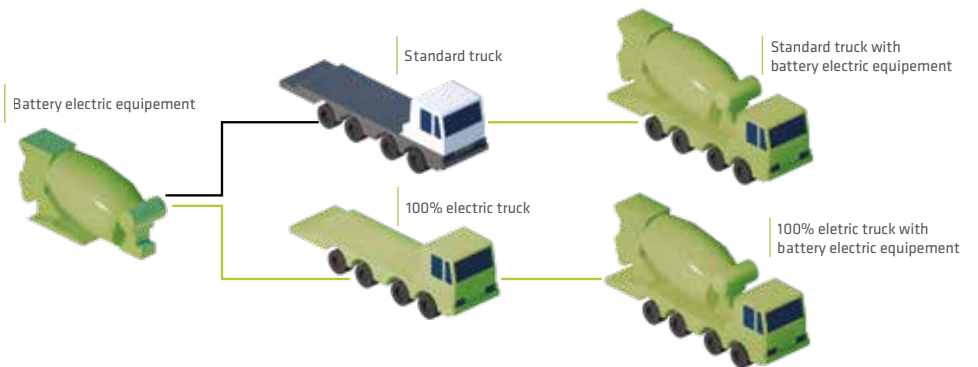

EE

ELECTRIC EQUIPMENT

CIFA designs electric equipment suitable to Battery Electric Vehicles. This combination is optimal for medium to small sized equipment, light upper structures and compact overall dimensions.

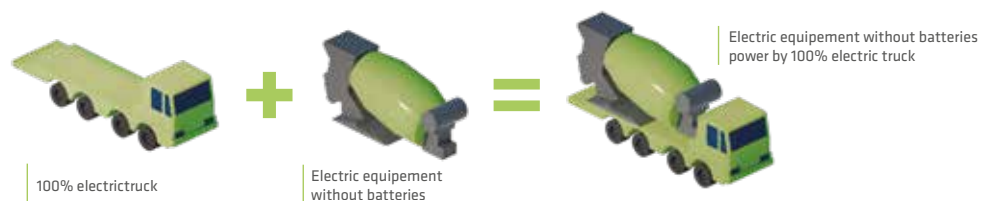

DESIGN IN LINE WITH THE ORIGINALITY OF THE PROJECT



Functionality
and robustness

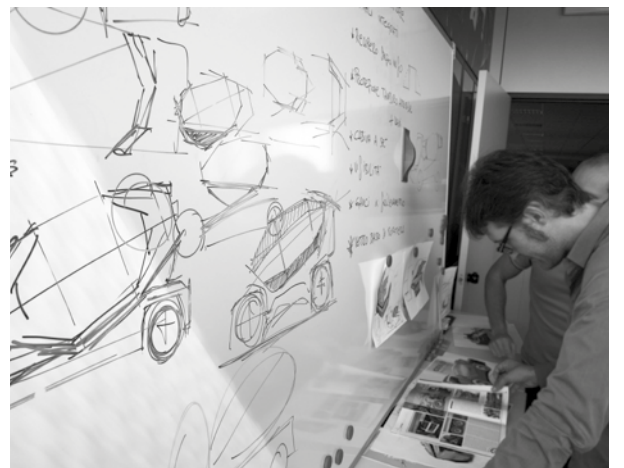

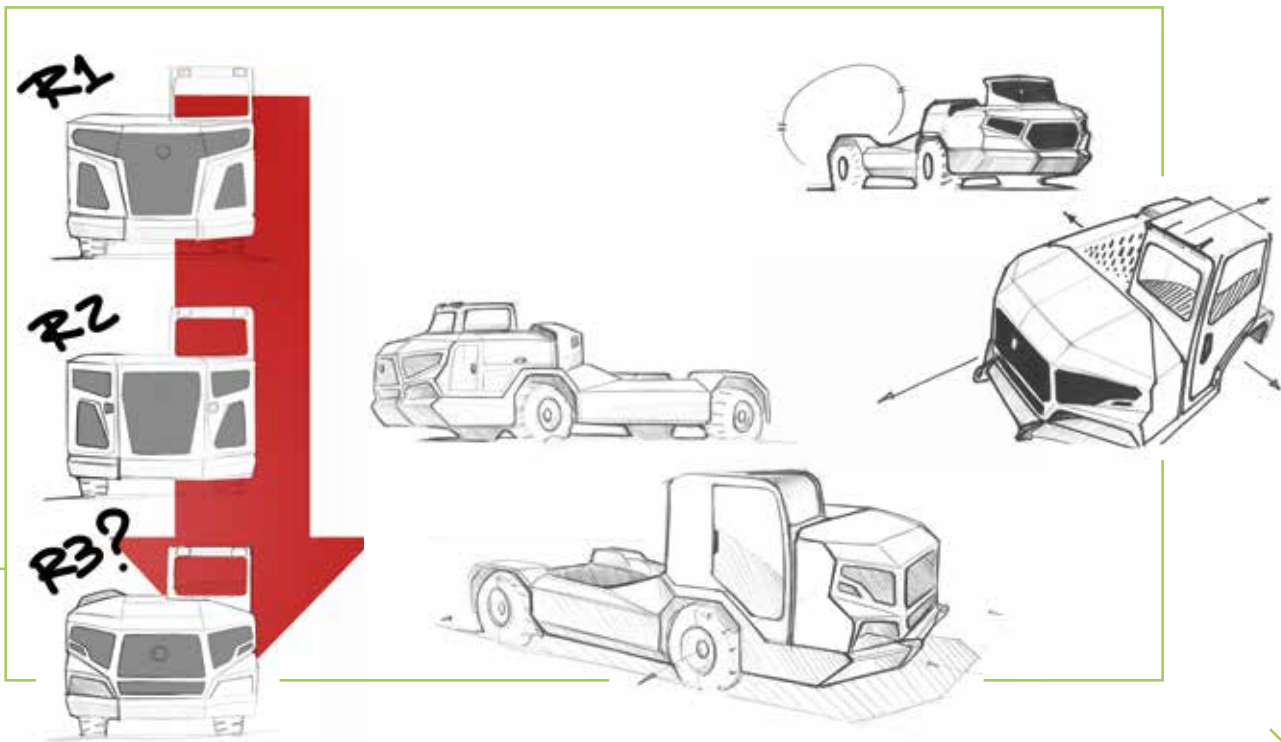

The international team of designers who created CIFA's ENERGYA hybrid range adopted the simple and meticulous approach used in the field of aeronautics, to enhance the functionality and solidity of the vehicle. It is therefore bold and powerful while also being slimline.

The design of the Energya range also combines special materials and high-tech solutions. As a result, this range is technologically advanced but also easy to use and pleasing in appearance.

Inspired by the shapes of aeronautics, the design of Energya combines strength and functionality.



reddot award 2014
winner

ENERGYA E9 WINS
RED DOT
DESIGN AWARD



reddot award 2017
winner

SPRITZ CSSE WINS
RED DOT DESIGN
AWARD



reddot award 2020
winner

ENERGYA MK 28E WINS
RED DOT DESIGN
AWARD

BATTERY ELECTRIC
TRUCK PUMP

ENERGYA K42E

A powerful truck pump that is battery electric driven without compromising on performance.

The K42E completes the ENERGYA range, which now boasts the first truck pump of its kind.

The K42E stands out for a number of technological innovations that revolutionise the concept of the truck pump but also, and most importantly, offers the same performance as a traditional model while reducing consumption and emissions.

The boom extends up to 42 m in 5 sections with the last two in carbon fibre: a unique feature of CIFA's CARBOTECH range and a smart way of optimizing the weight of the machine without reducing strength and reliability.

The K42E is equipped with a state-of-the-art system that uses a 30 Ah battery pack to power two electric motors: the first drives the hydraulic pump to move the boom and open the outriggers; while the second drives the pumping unit and other services.

The new ENERGYA pump can be connected directly to an electrical outlet at the construction site (three-phase). This means the system will continue to operate with the Diesel engine of the truck switched off and therefore without emitting exhaust gas and reducing noise.

In the case of a complete lack of electrical sources, it is possible to connect the K42E to the truck's power take-offs and therefore use the vehicle's engine to complete the pumping of concrete and close the boom and outriggers.

EUROPEAN
PATENT
PENDING



Fuel savings



No compromise on
performance



Less noise



100%
electric mode

ENERGYA K42E

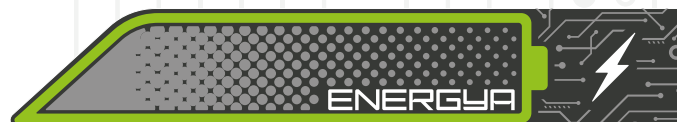

PUMPING UNIT TECHNICAL DATA

HP1608EC		
Max. theoretical production	m ³ /h	160
Max. pressure on concrete	bar	80
Concrete rods (diam.x stroke)	mm	230X2100
Hopper capacity	l	550
Hydraulic oil circuit	-	closed

ELECTRIC SYSTEM

Pumping unit motor	kW	90
Stabilization / Boom motor	kW	30
Electric power supply	V/A	380/63 380/125
Electric cable length	m	40

PLACING BOOM TECHNICAL DATA

B5ZR 42/38		
Pipeline diameter	mm	125
Max. vertical reach	m	41.1
Max. horizontal distance (from the center of the axis of rotation)	m	36.8
Min. unfolding height	m	8.3
Sections		5
1st section opening angle		90°
2nd section opening angle		180°
3rd section opening angle		180°
4th section opening angle		236°
5th section opening angle		223.5°
Rotating angle		+/-270°
End hose length	m	3

BATTERY

Type		Lithium-ion
Voltages	V	563.2
Power	kWh/Ah	28.2/50

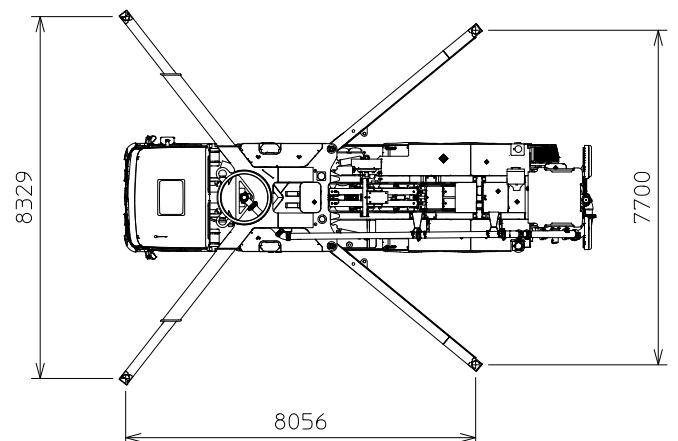
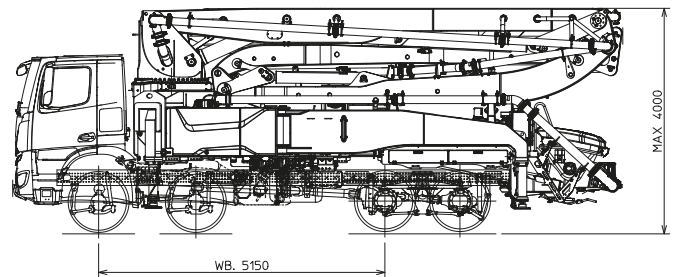
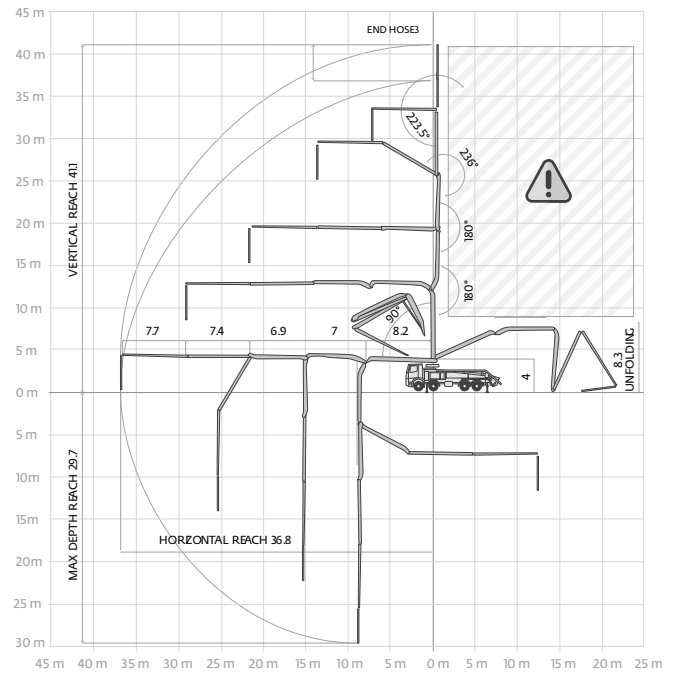

Closed circuit pumping unit from 160 m³/h to 80 Bar, electronic control and real time performance monitoring



40m power cord, direct connection to the job-site power grid to work in electric mode without limitations

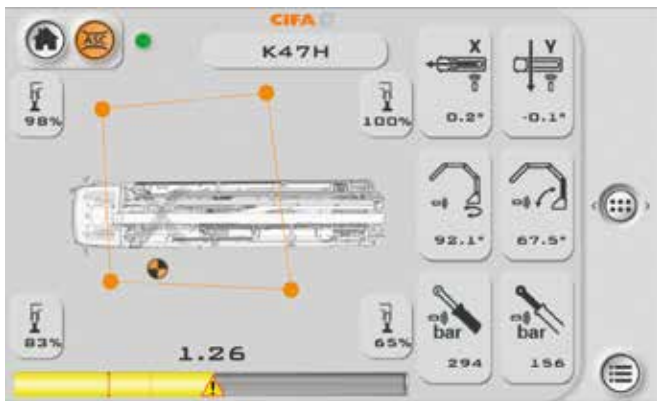
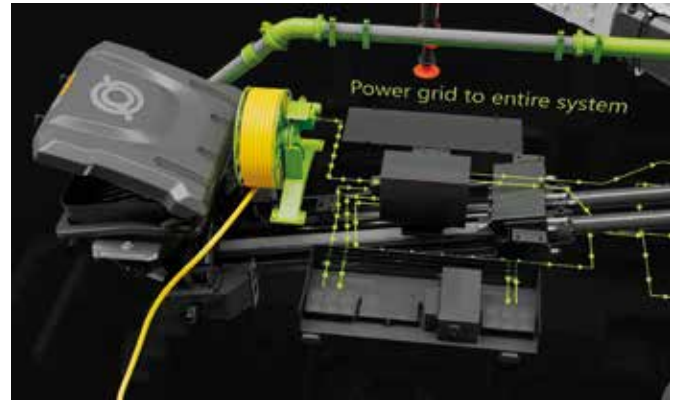

Smartronic Gold control system, 7" monitor, advanced stability control system (ASC), stabilization assisted boom system (MBE). Full control of all parameters anytime



Quick and easy to charge, the integrated battery charger is compatible with the 220V system

THE FIRST BATTERY
ELECTRIC PUMP MIXER

ENERGYA MK28E

The electrically managed functions relate to rotation of the drum, stabilization, opening/closing of the boom, and pumping.

The Energya concrete pump combines the popular and well-known engineering and operational features of the Magnum, a machine “invented” by CIFA, with the advantages of hybrid technology.

Thousands of Magnums have transported and cast millions of cubic metres of concrete around the world. CIFA has also designed and applied the carbon fibre technology to the structure of the boom, further evolving the concept of truck mixer pump. And now, with Energya, a new world record is set. It is a totally innovative truck mixer that is more fuel efficient, runs more quietly, pollutes far less and ensures greater freedom of movement.

ENERGYA MK28E is CIFA's modern electric concrete pump that uses the latest technologies to reduce fuel consumption, pollution and noise.

Its system permits complete control of energy in all working conditions, and the choice and fine-tuning of its components maximize its overall efficiency.

The conventional hydraulic system is operated by a high-efficiency electric transmission.

Its innovative technology allows to rotate the drum, operate the boom, set the outriggers and keep the pumping unit active with the diesel engine off, thereby minimizing exhaust gas emissions and keeping noise right down during loading and unloading operations at the construction site. The reduction of emissions and noise make ENERGYA very useful in densely populated areas and in all contexts where it is necessary to minimize environmental impact.



Fuel savings



No compromise on performance

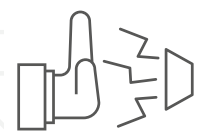

Less noise



100%
electric mode

ENERGYA MK28E

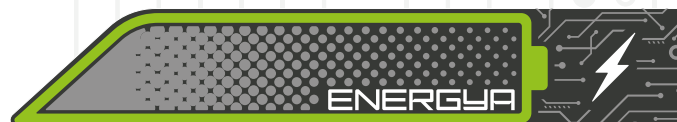

ENERGYA MK28E

CONCRETE MIXER TECHNICAL DATA

Model	RH 80	
Nominal capacity	m ³	7
Drum geometric volume	m ³	12.8
Filling ratio	%	55
Max. drum speed	r.p.m.	14
Pressurized water tank capacity	/	600
Liter-counter scale	/	0-500

PUMPING UNIT TECHNICAL DATA

Model	PB607EPC	
Max. theoretical output	m ³ /h	61
Max. pressure on concrete	bar	71
Max. number of cycles per minute	n	32
Concrete cylinders (diam. x stroke)	mm	200 X 1000
Concrete hopper capacity	l	400
"S" valve diameter	"	7

PLACING BOOM TECHNICAL DATA

Model	MK28H	
Pipeline diameter	mm	100
Max. vertical reach	m	27.150
Max. horizontal distance	m	23.274
Sections	4	
1st section opening angle	90°	
2nd section opening angle	180°	
3rd section opening angle	260°	
4th section opening angle	251°	
Rotating angle	-240° / +240°	
End hose length	m	4

BATTERY

Technology	Lithium-ion	
Voltage	358 V	
Capacity	38 kWh/105Ah	

CHARGING MODE

Standard charging mode	single phase 220V - 16A	
------------------------	-------------------------	--

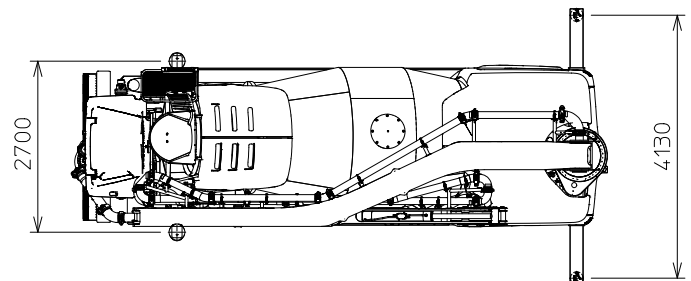
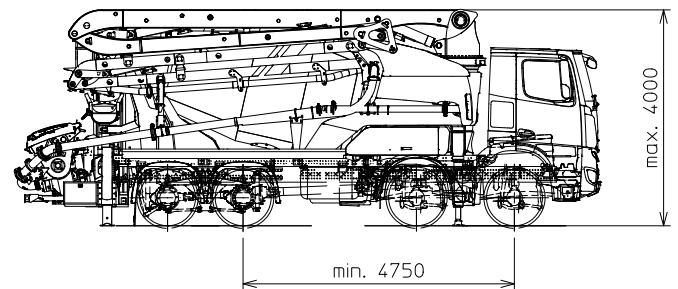
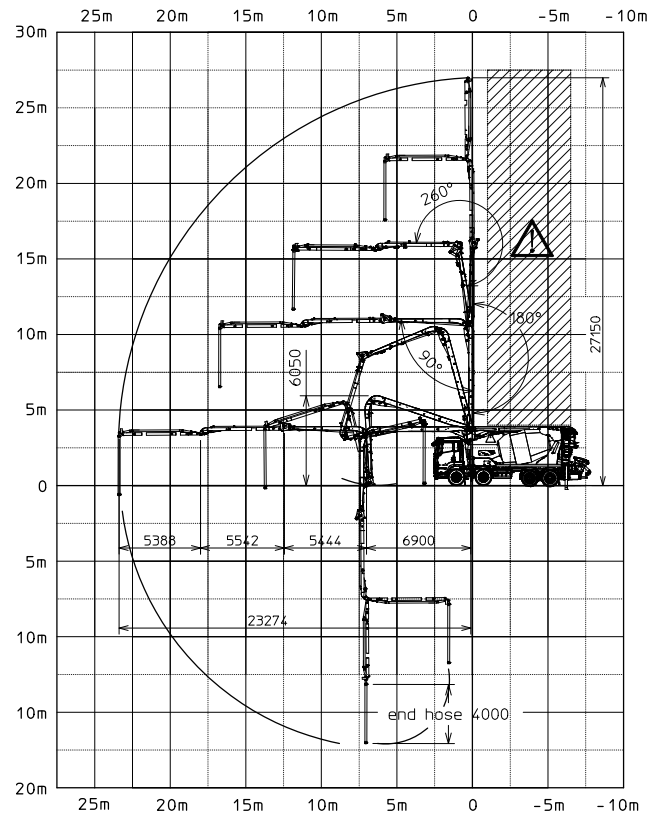

SOPHISTICATED BUT EASY TO USE

The ENERGYA concrete pump has integrated the best of CIFA technology for management of the mixer, pumping unit and boom.

The electronic control system, always at hand even in the driving cab, combines the ENERGYA module already present in its sister model, the E9, and the Smartronic system shared with the other concrete pumps. The latter allows you to precisely manage the closed-circuit pumping unit and, above all, to benefit from the LSC function for control of the stabilization system and work with maximum safety.



REAR MOBILE PANEL



Battery management



Smartronic with LSC system



Quick and intuitive control of operations with drum and discharge chute

The system is compatible with 220 V outlets and takes an average of 8 hours to charge.



THE FIRST BATTERY ELECTRIC TRUCK MIXER

ENERGYA E9 and E10

Electric on site, hybrid on the road.

The first machine ever with hybrid technology in the concrete transport sector, the ENERGYA TRUCK MIXERS are ENERGYA TRUCK MIXERS are based on an innovative drum handling system that allows to work in fully electric mode at the job-site.

In traditional cement mixers the movement of the drum is generated by a hydraulic system; in the ENERGYA series of truck mixers, on the other hand, it is generated by an electric induction motor that receives energy from a lithium ion battery. Thanks to the electrical operation, new opportunities are opening up for the transport of concrete, particularly in densely populated historic centres and in increasingly frequent scenarios, where lower environmental impact is an added value.

CIFA has created a new paradigm by profoundly changing the concept of the truck mixer and, above all, making it independent of the truck.

The movement of the drum of the mixer, in fact, is no longer directly linked to the power take-off of the truck but directly to an electric motor. The latter has also replaced the group of hydraulic pumps, simplifying the structure of the kit.

The engine of the truck is connected to a generator that recharges the batteries during transfer. This system, combined with the characteristics of the 28.1 kW / 100Ah Lithium-ion battery pack, guarantees autonomy throughout the working day.

In addition, the KERS (Kinetic Energy Recovery System) device is used to ensure a constant balance of the battery charge during transfer by exploiting the energy recovered during the braking phase.

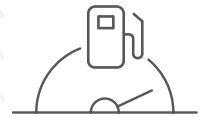

Fuel savings



No compromise on performance



Less noise



100% electric mode

ENERGYA E9 and E10



ENERGYA E9



ENERGYA E10



DRUM

Nominal capacity	m ³	9
Geometric volume	m ³	15.9
Filling ratio	%	56.3
Water line	m ³	10.2
Rotation speed	r.p.m.	0 ÷ 14
Diameter	mm	2300
Rollers	n	2
Water meter scale	/	0 ÷ 500
Water tank capacity	/	300
Water tank type		aluminum pressurized

DRIVEN BY

Electric motor	◆
----------------	---

DIMENSIONS

A - min. length of frame	mm	6670
B - min. length of mixer	mm	7633
C - overhang	mm	922
G - center of gravity	mm	3062
H - max. height *	mm	2735
Max width	mm	2500
Total weight (empty) **	Kg	4760

TRUCK SPECIFICATION

Truck axles	n	4
-------------	---	---

CHARGING MODES

Standard charging mode through on-board charger	Single-phase 220V - 16A
Battery	Lithium-ion

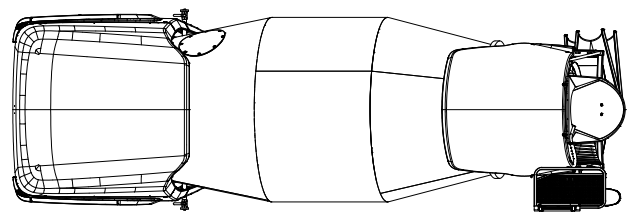
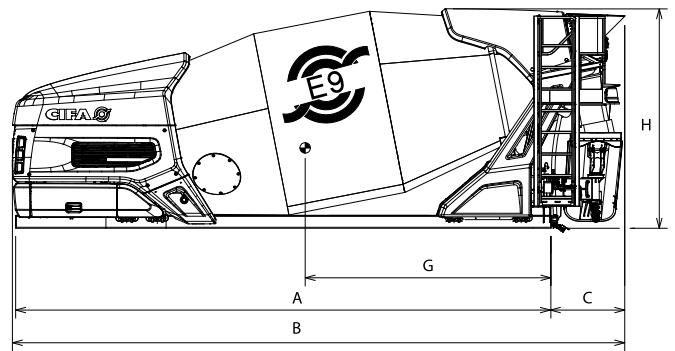
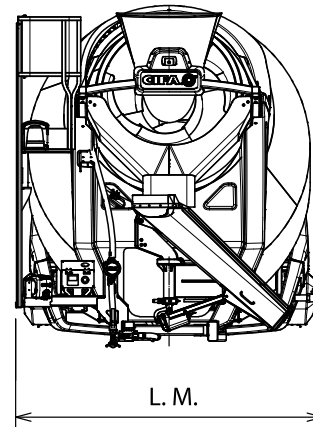

* CIFA standard frame
 ** Weights may vary ± 5% according to DIN 70200

INNOVATIVE IN EVERY RESPECT

The ENERGYA mixer is unique and therefore needs an advanced control and management system. In fact, all the information relating to the state of use and operation of the mixer can be checked at all times on the colour monitor installed in the driving cab of the truck. It is therefore possible to check all parameters and activate or manage the various functions while keeping an eye on the charge level of the battery.

There is an identical monitor at the back of the vehicle where there is also an analogue control pad.



Battery management



Rear monitor

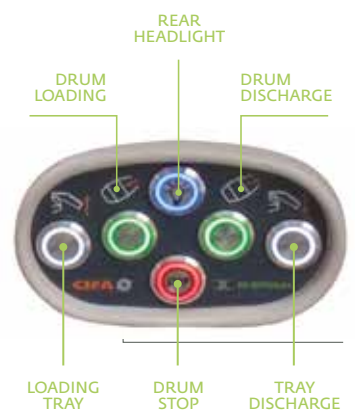

REAR MOBILE PANEL

DRUM

Nominal capacity	m ³	10
Geometric volume	m ³	16.2
Filling ratio	%	62
Water line	m ³	10.8
Rotation speed	r.p.m.	0 ÷ 14
Diameter	mm	2350
Rollers	n	2
Water meter scale	/	0 ÷ 500
Water tank capacity	/	800
Water tank type		Pressurized

DRIVEN BY

Electric motor	◆
----------------	---

DIMENSIONS

A - min. length of frame	mm	5930
B - min. length of mixer	mm	7228
C - overhang	mm	1116
G - center of gravity	mm	3007
H - max. height *	mm	2766
Max width	mm	2472
Total weight (empty) **	Kg	5186

TRUCK SPECIFICATION

Truck axles	n	4
-------------	---	---

CHARGING MODES

Standard charging mode through on-board charger	Single-phase 220V - 16A
Battery	Lithium-ion

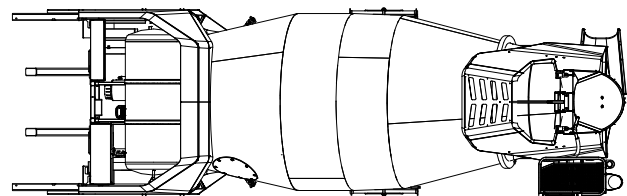
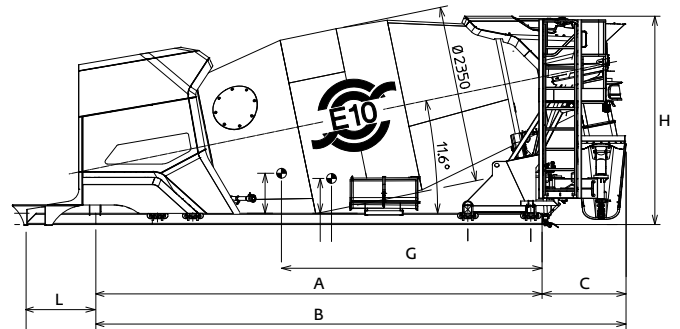
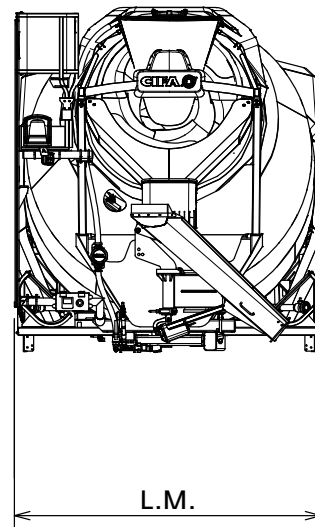

CSD ADVANCED

The evolution of the CSD system takes the form of a radio remote control that enables wireless control and operation of the concrete mixer for more immediate and convenient operation.

The remote-control body is robust, designed for work on a construction site, with a protective case and a magnetic belt hook. The control buttons are large, can be operated even with protective gloves, and is protected from liquids and dust.



ADVANCED FUNCTIONS

The display, which is clearly legible in all lighting conditions, presents operational information such as drum speed, hydraulic pressure, working hours, and also provides diagnostic messages to facilitate servicing and reduce downtime.

Specific functions are provided for loading concrete into the plant and for mixing it before unloading it on site pressing just a button.

THE FIRST FULL-ELECTRIC
TRUCK MIXER

ENERGYA SLE7

The ENERGYA technology
applied to a fully electric truck.

An even more agile and simple solution for a totally green technology.

The mixer kit is in fact free of any hydraulic system; the drum is driven directly by an electric motor, with a maximum power of up to 91 kW, mounted on the gear reducer.

The batteries used to operate the mixer are those of the truck: this ensures considerable savings in terms of weight and bulk and it is therefore possible to make the most of the capacity of the drum.



ENERGYA SLE7



DRUM

Nominal capacity	m ³	7
Geometric volume	m ³	12.2
Filling ratio	%	57
Water line	m ³	7.8
Rotation speed	r.p.m.	0 ÷ 14
Diameter	mm	2300
Rollers	n	2
Water meter scale	/	0 ÷ 500
Water tank capacity	/	400
Water tank type		aluminum pressurized

DIMENSIONS

A - min. length of frame	mm	5800
B - min. length of mixer	mm	6913
C - overhang	mm	1113
G - center of gravity	mm	2032
H - max. height *	mm	2590
Max width	mm	2355
Total weight (empty) **	Kg	3600

DRIVEN BY

Electric motor	◆
----------------	---

TRUCK SPECIFICATION

Truck axles	n	3
-------------	---	---

ENERGYA | DATASHEET

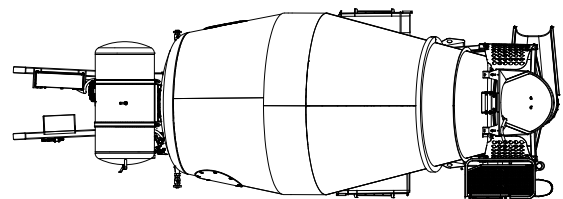
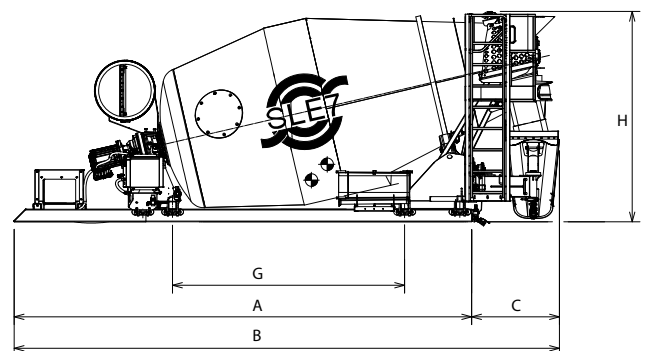
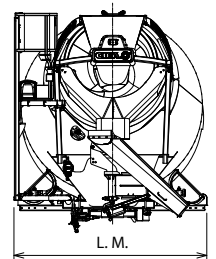

* CIFA standard frame
 ** Weights may vary
 ± 5% according to DIN 70200

MULTIPURPOSE VEHICLE

ENERGYA E-LIZARD

The vehicle can operate in electric mode during all the phases of operation.

Based on the COGUARO chassis, this new multipurpose mining vehicle combines innovation with versatility.

As its predecessor, the E-LIZARD is built on a heavy duty, low-height chassis featuring anti-skid 4WD and 4WS capabilities. With its shortwheel base and high ground clearance, it can easily handle tough off-road tracks.

Moreover, the E-LIZARD features a modular rigid chassis that is compact, easy to handle, and built for heavy-duty applications: its tailored upper structure is available ex-factory, making it adaptable for a wide range of plug-in accessories that include transport of solid materials, liquid transport, and material handling.

The vehicle operates efficiently in electric mode across all working stages. When connected to the mains, it can function while simultaneously charging its batteries, further extending its autonomy.

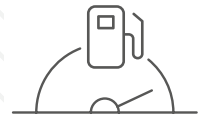

Fuel savings



No compromise on performance



Less noise



100% electric mode

ENERGYA E-LIZARD

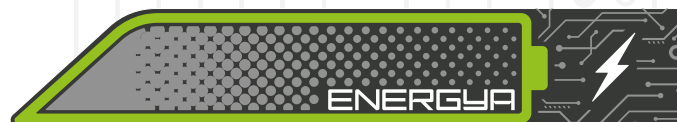

TRUCK CHASSIS TECHNICAL DATA

Model	E-LIZARD	
Installed power	kW	135
Turning circle	m	6.24
Wheelbase	m	3.6
Coupling angle		17°
Outlet angle		52°
Truck tyres		12.00 R20
Net Weight (dry)	Kg	6125
Max. Weight	Kg	21000

BATTERY

Technology	Lithium-ion	
Voltage	665 V	
Capacity	92.5 KWh / 139 Ah	

CHARGING MODE

Standard charging mode (on-board)	3-PHASE 380V/400V – 22KW	
Standard charging time (on-board)*	h	3.2
DC charging mode	65KW	
DC charging time	h	1.4

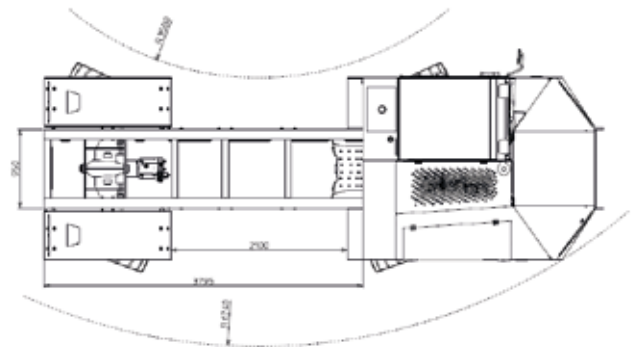
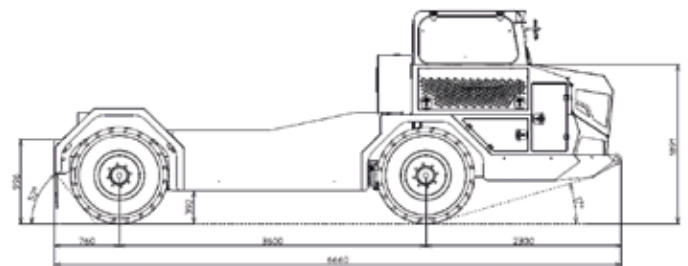
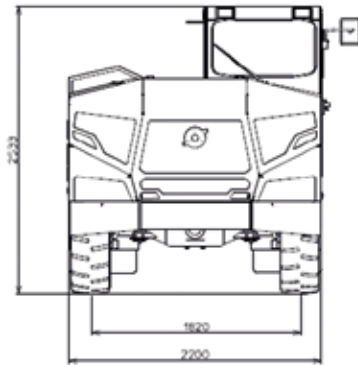

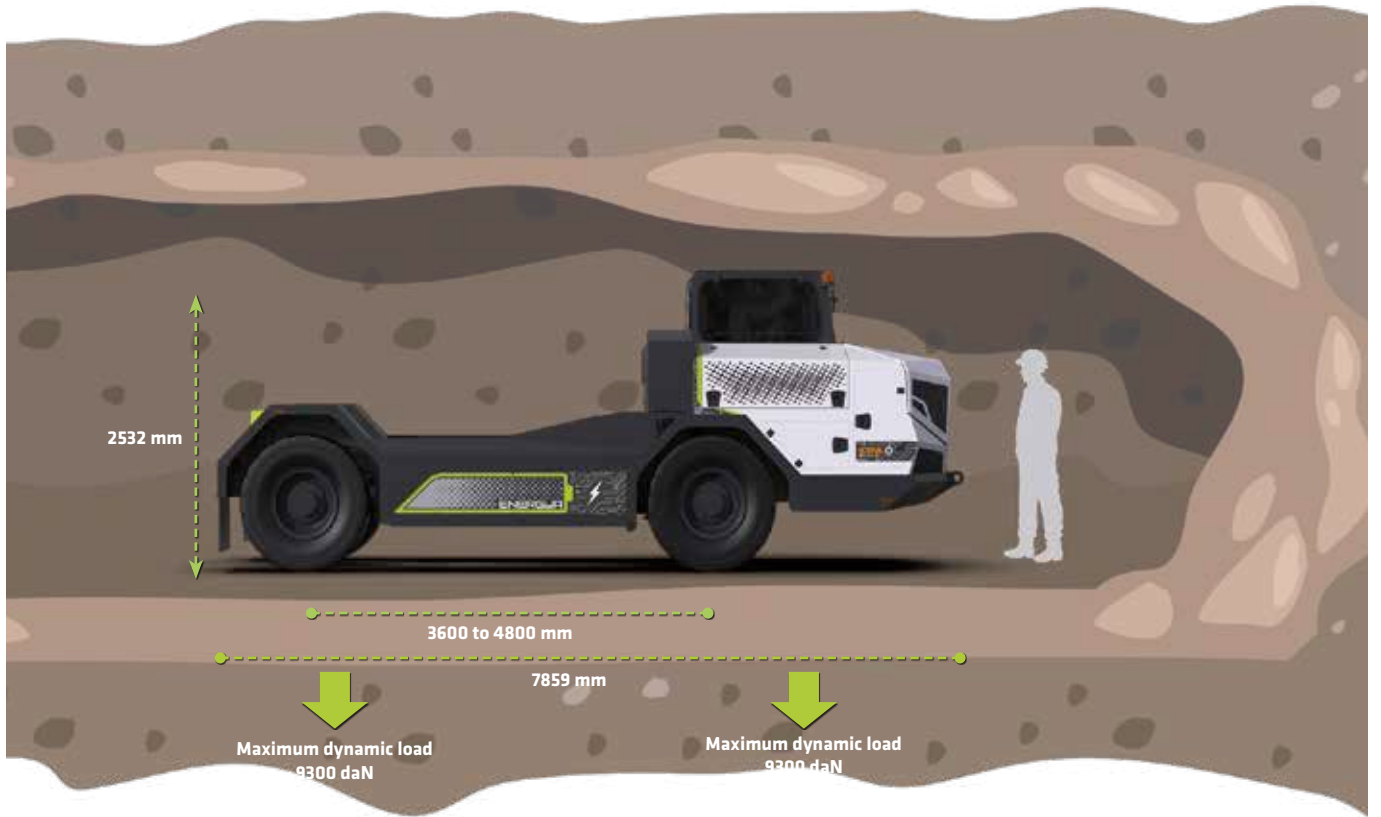

LIZARD ACCESSORIES POWERED BY BLEND

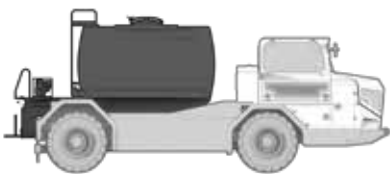

Liquid transport

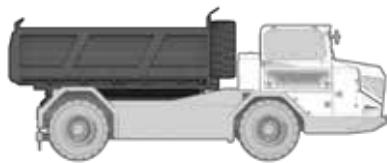

Solid transport

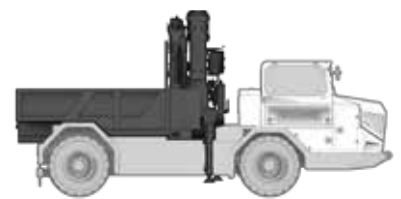

Material handling







ENERGYA



We offset the CO₂ production for the printing of this document by supporting LIFEGATE's Zero Impact project.



DEALER



CIFA S.p.A.
 Via Stati Uniti d'America, 26
 20030 Senago (Milano) - Italy
 Phone +39 02 990 131
 sales@cifa.com



www.cifa.com



The catalogue shows models, outfitting versions and configuration possibilities (standard and optional) of machines for the production, transport and pumping of concrete, manufactured and distributed by CIFA SpA. The catalogue is intended for general information purposes only and the information it contains shall not be deemed a contractually binding document, since CIFA SpA may make constructive and outfitting modifications at any moment and during the period between publication of the catalogue, the production of the equipment and the publication of a more updated catalogue.