

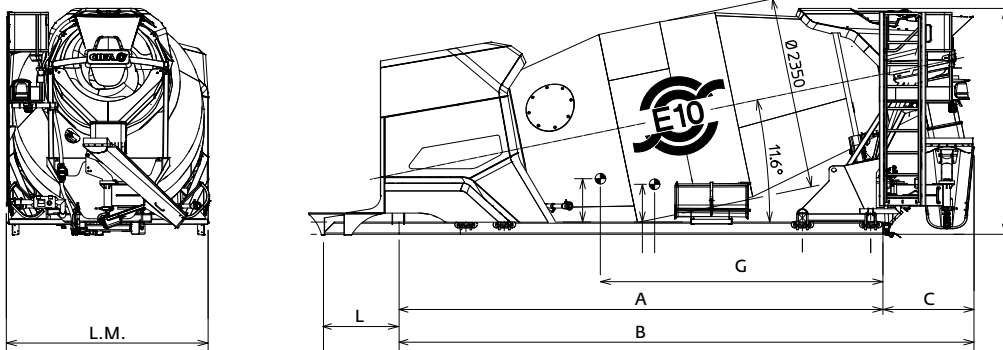

Dimensions



Energia

DRUM		E10
Nominal capacity	m ³	10
Geometric volume	m ³	16.2
Filling ratio	%	62
Water line	m ³	10.8
Rotation speed	r.p.m.	0 ÷ 14
Diameter	mm	2350
Rollers	n	2
Water meter scale	/	0 ÷ 500
Water tank capacity	/	800
Water tank type		pressurized
DRIVEN BY		
Electric motor		•

*CIFA standard frame

**Weights may vary ± 5% according to DIN 70200

Technical data and characteristics subject to modifications without notice

DIMENSIONS		E10
A - min. length of frame	mm	5930
B - min. length of mixer	mm	7228
C - overhang	mm	1116
G - center of gravity	mm	3007
H - max. height*	mm	2766
Max width	mm	2472
Total weight (empty)**	Kg	5186

TRUCK SPECIFICATION

Truck axles	n	4
-------------	---	---



CHARGING MODES

Standard charging mode through on-board charger	Single-phase 220V - 16A
High speed charging mode	DC current 300V - 80A

BATTERY

Technology	Lithium-ion
Capacity	281,6V - 105Ah - 29,5kWh

ENERGYA

Electric plug-in mixer

E10



Product description

ENERGYA is the new CIFA plug-in Hybrid truck mixer adopting the latest technologies to decrease fuel consumption, pollution and noise. The system allows the full energy management in all working conditions and the choice and the set up of components maximize the general efficiency of the system. Conventional hydraulic system is replaced by electric transmission with high efficiency. The system allows to rotate the drum with diesel engine off, without exhaust emission and with very low noise in the working area during the charging and discharging phases. Emission and noise reduction make ENERGYA very useful in all areas where high respect for the environment is the first choice.

Standard equipment

- Basic frame, straight or shaped, made profile according to truck manufacturer specifications
- Drum design according to DIN459 norm with large loading volume with high water line
- Drum and blades made of 450 HB steel
- Wear protected blades
- Two rollers diam. 250 mm with special off road support, completely bolted for an easy maintenance and adjusting
- Pressurized aluminum water tank capacity 800 l
- Two washing nozzles (one at ground level by quick joint and one on ladder platform)
- Concrete manometer for concrete consistency shown in displays
- Two light additional chutes in iron-plastic material, with supports for their fixing
- Special design charging hopper and discharging hopper and chute for a fast and smooth charging and discharging, completely bolted for a better and simple maintenance
- Wear plates on charging hopper and discharging chute
- Discharging chute driven by manual cylinder
- No. 2 quick joint water fillers on sides of front supporting frame
- Rear camera, cyclist guard twin bars and protection tilting rear bar (standard EEC area)
- Fiber-glass back protection on rear support easy to clean
- Two strong armed swivel chute system
- Polymer rear mono-axle mudguards with rubber mudflaps
- Sliding aluminum ladder
- Two man holes on the drum and two safety drum locking systems
- Water meter
- Electronic control system, including one control panel in the cab and one control panel with 3m cable placed in the mixer rear side to control the drum during the road transfer and operations
- Special design including fiber-glass covers
- LED rear light

Main options

- Aluminum pressurized water tank (500 l)
- 2 additional aluminum chutes
- Additive pressurized tank (50 l)
- Additional LED rear light
- Discharging chute driven by electric cylinder
- Energya Fast Charge charging station 300V DC current



BEE*

the Change

*BEE Battery Electric Equipment

Efficiency in sustainability:
this is the commitment of a range
of machines unique in the world.